

FilterCart Advanced+

Mobile Filter for Intermittent Duty Fume

Effective and User-Friendly Fume Extraction Solution

FilterCart Advanced+ is an effective, convenient and easy to use engineering control that protects workers from the harmful effects of welding fume as recommended by global health and safety organizations. Designed for light and intermittent duty fume applications, the FilterCart has a small footprint and lightweight construction making it easy to move and place inside tight workspaces. Despite the small package, the unit is full of technology and features that make it easy to own and operate.

Reliable and Effective Capture

Protecting welders from the harmful effects of weld fume control begins with capturing the fume effectively at the source. The FilterCart's extraction arm is easily positioned and features an optimized hood design that expands the fume capture zone.

Enhanced Filter Technology

FilterCart Advanced+ features a MERV 14 Nanofiber filter effective at removing the fine metal and smoke particles from the air stream and extends the filter life with higher dust holding capacity. The filter construction includes a multi-layer mesh inner liner to help arrest sparks and fire retardant media to reduce the risk of fire. An optional HEPA after filter is available for high-toxicity fume including hexavalent chromium.

Simple to Use and Operate

Ensuring proper airflow is critical in effectively capturing the weld fume and the FilterCart includes a digital filter life indicator and audible alarm to inform the user when maintenance is required. Filter maintenance is tool-free and can be performed in a matter of minutes ensuring that welders remain productive.



Optional HEPA after filter
Additional filtration efficiency for difficult or toxic applications.

Filter media technology
Standard Nanofiber, fire retardant filter technology that efficiently removes weld fume (MERV 14).

Airflow and filter life indicator
Sensors measure if adequate airflow and visually/audibly notify users when maintenance required to ensure effective fume capture.



Original extraction arm
Best-in-class arm that is easy to locate and reliably hold its position.

Original hood
Designed for efficiency and ergonomic handling.

Narrow footprint
Allows for easy maneuverability through regular sized doors.

Durable mobility
Large diameter rear wheel for easy mobility in an industrial environment. Locking front casters to hold in place during use.

FilterCart Advanced+

Models and Specifications

Model	Arm Length ft (m)	Arm Diameter in (mm)	Air Flow cfm (m ³ /h)	Filter Load Indicator	Filter Area* ft ² (m ²)	Power Hp (kW)	Supply Power	Noise Level (dBA)
FilterCart Advanced+	10 (3)	6 (152)	620 (1,053)	Audible	323 (30)	1 (0.7)	120V/ 1PH/ 60Hz	73

*Filter area based on Nanofiber fire retardant media. All models evaluated for compliance in accordance with NEC and UL codes.

Product Dimensions mm (inches)

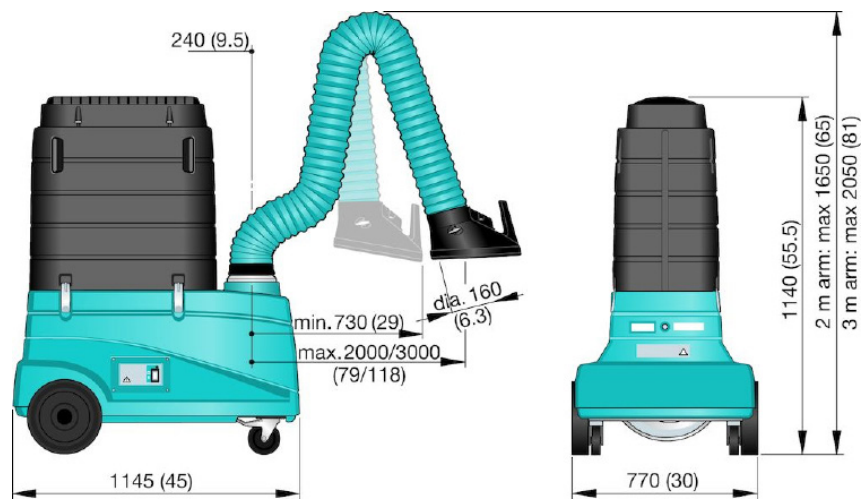

Accessories and Replacement Filters

Options	Description
Filter media	MERV 14 Nanofiber Filter
Spotlight	Hood mounted light kit for improved visibility. Includes unit on/off switch
Secondary filters	Certified H13/H14 HEPA filters

Nederman offers genuine replacement filters, spare parts and accessories to keep your equipment operating at maximum efficiency. Contact a local Nederman representative today or visit our spare parts search: www.nederman.com/en-us/service/spare-part-search



Our facilities are
ISO 14001:2015 certified